

DELUXE55

• TWEED RECREATION •

OWNER'S MANUAL



www.origineffects.com

ORIGIN EFFECTS is a trademark of Origin Effects Limited and is a registered trademark in the United States, United Kingdom, China and the EU.

The ORIGIN EFFECTS Totem Device is a trade mark of Origin Effects Limited and is a registered trademark in the United States, China and United Kingdom.

DELUXE55 is a trademark of Origin Effects Limited.

FENDER® is a registered trademark of Fender Musical Instruments Corporation. Origin Effects has no affiliation with Fender Musical Instruments Corporation.

MARSHALL® is a registered trademark of Marshall Amplification Plc.

Origin Effects has no affiliation with Marshall Amplification Plc.

All other product names and trademarks are the property of their respective owners and are hereby acknowledged.

No part of this publication may be reproduced in any form or by any means, whether mechanical or electronic, without the written permission of Origin Effects Limited.

Origin Effects Limited reserves the right to change the features and specifications described herein without notice or obligation. Origin Effects Limited cannot be held responsible for any loss or damage arising directly or indirectly from any error or omission in this manual.

© Origin Effects Limited 2024

Origin Effects LTD
Unit 4, Top Angel, Buckingham
Buckinghamshire, MK18 1TH
United Kingdom



Contents

Safety Notices	4
Safety Instructions	5
Introducing the DELUXE55 Tweed Recreation	6
What is Amp Recreation?	6
DELUXE55 in Your Rig	7-8
DELUXE55 Internal Signal Flow Diagram	9
Connecting the DELUXE55 Tweed Recreation	10
Controls	10-11
Origin Effects IR Cab Library	11
Sample Settings	12
Appendix A: Physical Specification	13
Appendix B: Performance Specification	13
Appendix C: Connector Pin Out	13
Appendix D: Environmental Information	14
Appendix E: Directives & Regulations	14
Appendix F: Warranty	15

Safety Notices:

General Information:

This document contains important information for the safe operation of the product. Read and follow the safety instructions and all other guidance. Our products and documentation are subject to a process of continuous development. They are therefore subject to change. Please refer to the latest version of the documentation, which is available on our website <https://origineffects.com/manuals/>.

Keep these instructions and heed all warnings. Do not use this apparatus near water. Clean only with a dry cloth. Do not install near any heat sources such as radiators, stoves or other apparatus (including amplifiers) that produce heat. Refer all servicing to qualified service personnel.



NOTICE!

Damage may be caused to the device should it be tampered with!

No user-serviceable parts inside. In the event of damage to the unit, service or repair must be done by qualified service personnel only.

Symbols and signal words:

In this section you will find an overview of the meaning of symbols and signal words that are used in this document.

Signal Word	Meaning
DANGER!	This combination of symbol and signal word indicates a dangerous situation that could result in serious injury or even death if it is not avoided.
WARNING!	This combination of symbol and signal word indicates a potentially dangerous situation that could result in serious injury or even death if it is not avoided.
NOTICE!	This combination of symbol and signal word indicates a potentially dangerous situation that could result in material and/or environmental damage if it is not avoided.

Warning Symbol	Meaning
	Warning - dangerous situation

Safety Instructions:

Intended use:

This device is intended for use as effects pedal for sound processing of signals from musical instruments with electromagnetic pickups. Any other use or use under other operating conditions is considered to be improper and may result in personal injury or property damage. No liability will be assumed for damages resulting from improper use.

Safety:



DANGER!

Risk of injury and choking hazard for children!

Children can suffocate on packaging material and small parts. Never allow children to play with packaging material or the device. Always store packaging material out of the reach of babies and small children. Always dispose of packaging material properly when it is not in use. Never allow children to use the device without supervision. Keep small parts away from children and make sure that the device does not shed any small parts (such as knobs, rubber feet) that children could play with.



WARNING!

Possible hearing damage due to high volumes on speakers, headphones, bass & guitar amplifiers!

With loudspeakers or headphones connected, the device can produce volume levels that may cause temporary or permanent hearing impairment. Over an extended period of time, even levels that seem to be uncritical can cause hearing damage. Do not operate the device permanently at a high volume level. Decrease the volume level immediately if you experience ringing in your ears or hearing impairment and seek medical advice.



NOTICE!

Damage to device if powered incorrectly!

This product is designed to be powered from a 9VDC, >100mA power supply with 2.1mm centre-negative barrel connector. Use of an incorrectly rated power supply could result in damage to the pedal and the power supply.



NOTICE!

Possible staining due from rubber feet!

The plasticiser used in the manufacture of the rubber feet on this product may react with floor coatings and result in permanent dark stains after some time. If necessary, use a suitable mat to prevent direct contact between the device's rubber feet and the floor.

Introducing the DELUXE55 Tweed Recreation

The DELUXE55 is our all-analogue tribute to the legendary Fender® 5E3 Tweed Deluxe from 1955. With a complete valve amp signal path recreated in miniature using carefully crafted transistor-based circuitry, this compact pedal nails the sound, feel and personality of one of history's quirkiest combos. It's warm yet cutting, soft yet punchy, with tones ranging from articulate edge-of-breakup to thick leads and all-out, about-to-explode fuzz!

The DELUXE55 accurately captures this tone – rough around the edges and full of character. The sound of 6V6 power amp overdrive, valve rectifier sag, ragged phase inverter distortion, and the fat gritty tone of the 5E3's unconventional preamp – including different valve types. It's all here in the DELUXE55, ready to drop into any rig.

Key Features:

- Faithfully recreates the sound and feel of the 1955 Fender® Tweed Deluxe
- Complete, valve amp-style signal path recreated in all-analogue circuitry
- Simulated push-pull power amp with reactive load
- Preamp switch selects between 12AY7 and 12AX7 valve character
- Post EQ ensures compatibility with any rig
- Ultra-high input impedance
- High-quality buffered bypass
- Premium components throughout
- Designed and built in England

What is an Amp Recreation?

Amp Recreation is the name we give to our range of all-analogue pedals that recreate the sound and feel of desirable vintage valve amplifiers. Our Amp Recreations can be used in place of an amplifier in an “ampless” rig. They can replace an amp block in a modeller to give a more realistic amp tone. They can be used into a power amp and cab, and of course they can be run into the front end of a traditional guitar amp.

When we say “Amp Recreation”, we really mean it! Each Amp Recreation pedal contains the complete signal path of a vintage valve amplifier, except the valves! We use carefully designed transistor-based circuitry to capture every tiny detail of the real amps' circuitry, informed by many hours of meticulous testing and measurement with the original amps. These pedals contain a preamp stage, phase inverter, simulated push-pull power amp, reactive load and even rectifier sag! All these are crucial to providing the authentic tones and the playing experience of vintage amps.

We then add a POST EQ filter after the amp recreation circuit. This ensures total compatibility with the preamp circuitry in traditional guitar amps. This means you don't have to compromise your amp's tone to get the most out of your Amp Recreation pedal, or vice versa.

DELUXE55 in Your Rig



WARNING!

Possible hearing damage due to high volumes on speakers, headphones, bass & guitar amplifiers!

With loudspeakers or headphones connected, the device can produce volume levels that may cause temporary or permanent hearing impairment. Over an extended period of time, even levels that seem to be uncritical can cause hearing damage. Do not operate the device permanently at a high volume level. Decrease the volume level immediately if you experience ringing in your ears or hearing impairment and seek medical advice.

DELUXE55 with a Traditional Amp:

When running the DELUXE55 into a traditional amp, place it after any pedals that you'd typically use near the start of your chain, such as fuzz, wah, compression and overdrive. Place time-based effects such as modulation, delay and reverb after your DELUXE55. If your amp has an FX loop for your time-based effects, the DELUXE55 should still be used before your amp's input.

We also need to consider the amp's preamp voicing. A traditional amp shapes the sound considerably. For example, boosting treble and cutting mids. The DELUXE55's POST EQ control counteracts this effect so that the DELUXE55 always sounds right, without you needing to adjust your amp's controls. For best results, set your amp clean and select POST EQ mode I or II (see page 11 for details).

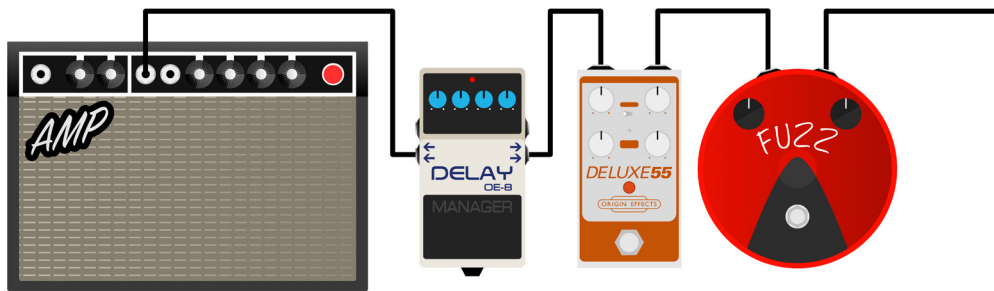

Amplified Rig with Separate Pedals:

Treat your DELUXE55 pedal like the amp in your signal chain. Place it after any pedals that you'd typically use in front of an amp's input, such as fuzz, wah, compression and overdrive. Place time-based effects such as modulation, delay and reverb after your DELUXE55. In this kind of rig, you'll need a cabinet simulator. This should be placed after your DELUXE55 and modulation pedals, and before or after delay and reverb depending on your preference. Set the Post EQ to FLAT (see page 11 for details).

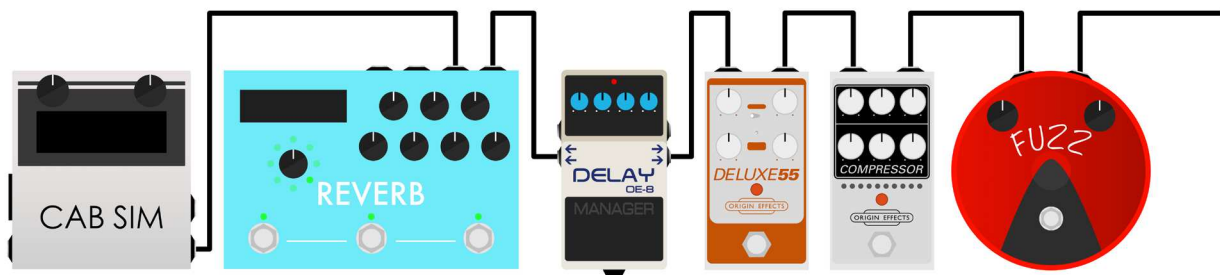

DELUXE55 in Your Rig (continued)

Replacing an Amp Block in a Modeller:

Like the example above, the DELUXE55 takes the place of an amp in your signal chain. With a modeller, you will need to connect the DELUXE55 in the modeller's FX Loop. When building a preset, use the FX Loop block in place of an amp block. Place the FX Loop block after compression and drive and before time-based effects. Set the POST EQ to FLAT (see page 11 for details).

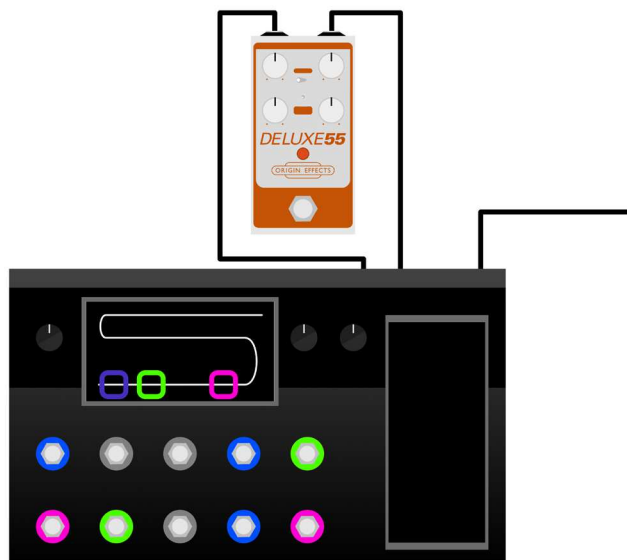

DELUXE55 with a Power Amp and Cab (or Amp FX Return):

Just like the previous two rigs, the DELUXE55 is being used as the main “amp sound”. Place after compression, overdrive etc. and before time-based effects. Connect the output from your last pedal to your power amp's input (or amp's FX Return) and set the POST EQ to FLAT (see page 11 for details).

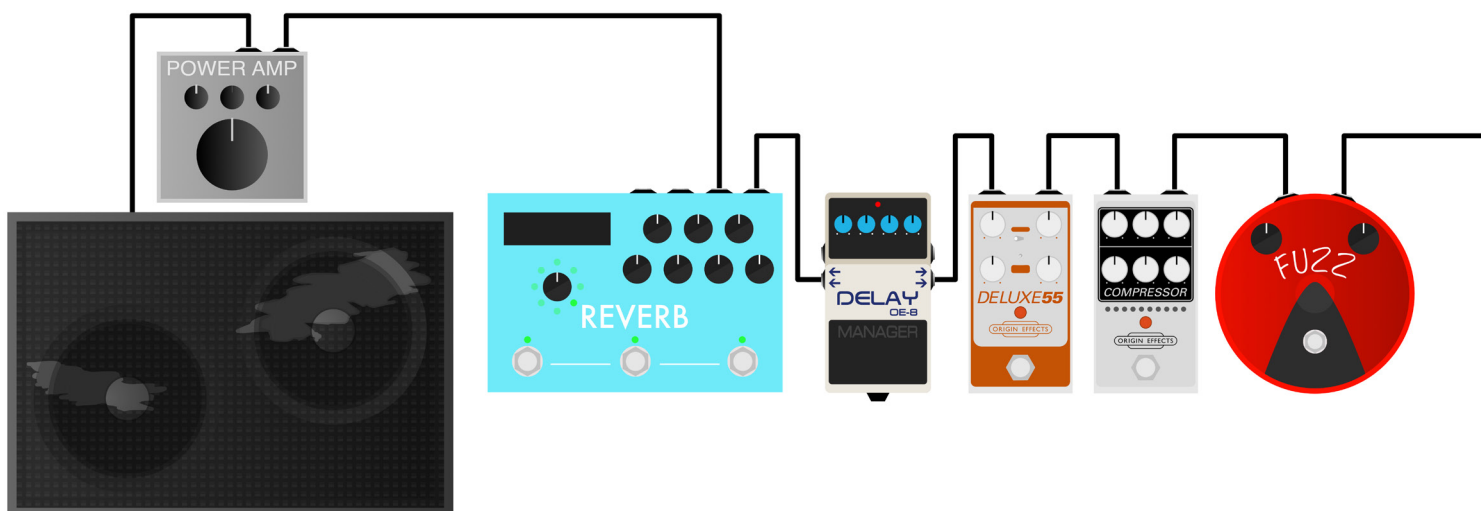

DELUXE55 Internal Signal Flow Diagram:

What goes into an Amp Recreation pedal? The diagram below shows how the different parts of the Tweed Deluxe amp have been recreated in the DELUXE55. For example, all the parts of the circuit that recreate valve stages are affected by simulated rectifier sag. The POST EQ is separate from the Amp Recreation circuitry and does not affect the character of the overdrive.

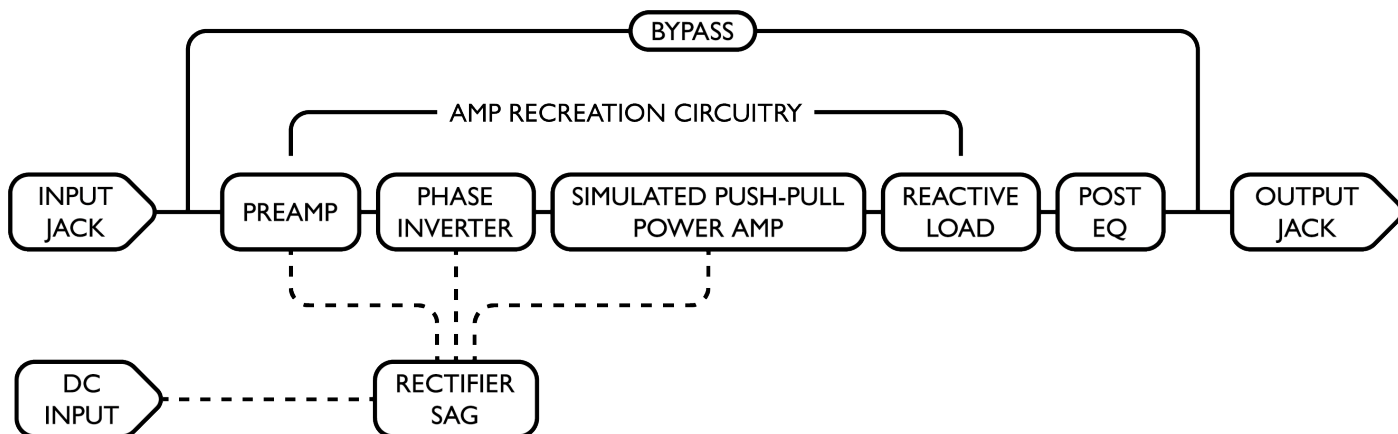

Connecting the DELUXE55 Tweed Recreation



9VDC: Connect a 9VDC 2.1mm centre-negative mains power adaptor (minimum 100mA).



NOTICE!

Damage to device if powered incorrectly!

This product is designed to be powered from a 9VDC, >100mA power supply with 2.1mm centre-negative barrel connector. Use of an incorrectly rated power supply could result in damage to the pedal and the power supply.

INSTR: Connect to your guitar.

AMP: Connect to your amp or modeller.

Controls



DRIVE: Turn clockwise to increase the amount of overdrive. Very low settings will result in an excellent clean tone, before moving into crunch, then heavily overdriven sounds. Like a real Tweed Deluxe, very overdriven sounds will sound fuzzy, fat and compressed – and lots of fun! The DRIVE control is interactive with the TONE control and PREAMP switch (see below).

LEVEL: Sets the output level from the pedal. Turn clockwise to increase overall volume. When using with a traditional amp, best results will be achieved with a clean tone on your amp. Compare the pedal's tone with the bypass signal to ensure you are not unintentionally adding volume and boosting your amp.

TONE: Turning clockwise will increase the amount of treble, resulting in a brighter sound. Turning counterclockwise will remove treble, resulting in a darker sound. Like a real Tweed Deluxe, the TONE control will also increase overall gain above 2 o'clock. To counter this, reduce the DRIVE control when using higher TONE control settings.

Controls (continued)

PREAMP SWITCH: This switch reconfigures the pedal's preamp stage to mimic swapping a 12AY7 valve for a 12AX7 valve – a popular modification for the Tweed Deluxe. Each mode has a different tonal character.

12AY7: This mode has less gain and a brighter tone, great for articulate edge-of-breakup and crunch tones.

12AX7: This mode adds more gain and reduces treble. The 12AX7 mode also lowers the frequency at which the tone control operates. This higher gain, darker setting delivers warm lead tones and gives access to over-the-top, fuzz-like Tweed distortion.

POST EQ: The Post EQ circuit is a filter placed after the Amp Recreation circuitry, ensuring compatibility with a variety of setups. By tailoring the output of the pedal to suit the voicing of different amps, you no longer need to sacrifice your amp's clean tone to get the best out of your pedal.

POST EQ MODE SWITCH:

I: This setting is designed to match with the voicing of Black Panel Fender® amps and other bright-sounding amplifiers.

II: This setting is designed to match with the voicing of Marshall®-style amps and other amplifiers with a darker, more mid-rich sound.

FLAT: This setting is designed to be used with cabinet simulators or neutral power amps and guitar speaker cabinets. Because these devices do not have an in-built voicing in the way traditional guitar amps do, no filtering is required. The FLAT setting gives you the unadulterated sound of the DELUXE55.

POST EQ KNOB: When the POST EQ MODE switch is set to I or II, this control adjusts the shape of the filter applied to the pedal's output. This allows you to further tweak the sound of the DELUXE55 to match your preferred amp settings. Turning clockwise will increase bass while reducing treble. Turning counterclockwise will decrease bass while increasing treble. This control is inactive when the POST EQ

Origin Effects IR Cab Library

For those using the DELUXE55 with impulse responses, you can download the Origin Effects IR Cab Library absolutely free at origineffects.com. These high quality impulse responses were created using our own collection of vintage cabs and combos, including an original Fender Tweed Deluxe amp. Load your IR, set the POST EQ to FLAT and enjoy authentic Tweed tones!



Sample Settings



BRIGHT CRUNCH

Full of unique vintage character but also incredibly versatile. This tone has plenty of presence, fullness in the mids and responds brilliantly to dynamic playing. A real all-rounder that never loses that Tweed personality.



STUDIO LEAD

The secret ingredient to some of the best recorded lead tones in rock history! The 12AX7 mode on the PREAMP switch guarantees plenty of gain and warmth, while the DRIVE knob keeps things sounding thick but under control.



FULL MELTDOWN

The textbook “amp about to explode” tone! Switch to 12AX7, crank it all up and enjoy an unhinged, collapsing wall of fuzz. With undeniably amp-like compression and saturation, this tone is a lot of fun to play.



ALMOST CLEAN

Tweed Deluxe tones aren't all about overdrive. Turning down the DRIVE knob and selecting 12AY7 reveals a warm clean tone with just a hint of breakup, like something straight off a '50s jazz record.

Appendix A: Physical Specification

Measurement	Unboxed	Boxed
Weight	500g (18oz)	570g (20oz)
Length	124mm (4.8")	135mm (5.3")
Depth	64mm (2.5")	90mm (3.5")
Height	58mm (2.3")	85mm (3.3")

Appendix B: Performance Specification

Measurement	Value
Input impedance	1M Ω
Output impedance	1k Ω
Current draw	100mA
Power supply requirements	9VDC 2.1mm centre negative connector

Appendix C: Connector Pin Out

Instrument & Amplifier 1/4" TS Sockets:

Pin	Description
Tip	Signal
Sleeve	Ground

Appendix D: Environmental Information



The crossed out wheeled bin symbol indicates this product is classified as Waste Electrical and Electronic Equipment (WEEE) in the European Union and should not be discarded with household waste. Other territories may vary. Contact your local authority or Origin Effects for more information.



The packing materials for this product are recyclable. Do not dispose of these materials with your normal household waste. Please refer to the symbols on the packaging for recycling information. Contact your local authority for further guidance on recycle in your region.

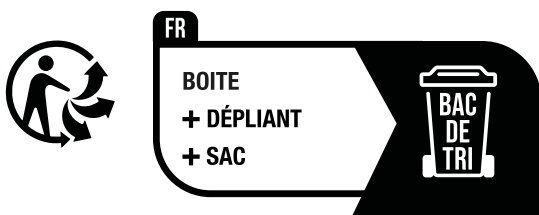

Points de collecte sur www.quefairedemesdechets.fr
Privilégiez la réparation ou le don de votre appareil !

Scatola	Volantino	Borsa
PAP20	PAP22	LDPE4
Raccolta Carta	Raccolta Carta	Raccolta Plastica

Controlla le linee guida locali per la raccolta

CARTÃO	PAPEL	PLÁSTICO
Esvaziar Espalmar	Separar	Esvaziar



Appendix E: Directives & Regulations



This product complies with Electromagnetic Compatibility (EMC) directive 2014/30/EU.



Origin Effects Ltd has conformed where applicable to European Union's Directive 2011/65/EU on Restrictions of Hazardous Substances (RoHS) as well as the following sections of California law which refer to RoHS, namely sections 25214.10, 25214.10.2, and 58012, Health and Safety Code; Section 42475.2, Public Resources Code.



This equipment has been tested and found to comply with the limits for a Class B device, pursuant to part 15 of the FCC Rules. These limits are designed to provide reasonable protection against harmful interference in a residential installation. This equipment generates, uses and can radiate radio frequency energy and, if not installed and used in accordance with the instructions, may cause harmful interference to radio communications. However, there is no guarantee that interference will not occur in a particular installation. If this equipment does cause harmful interference to radio or television reception, which can be determined by turning the equipment off and on, the user is encouraged to try to correct the interference by one or more of the following measures:

- Reorient or relocate the receiving antenna.
- Increase the separation between the equipment and receiver.
- Connect the equipment into an outlet on a circuit different from that to which the receiver is connected.
- Consult the dealer or an experienced radio/TV technician for help.

Appendix F: Warranty

At Origin Effects we want you to have a long and happy relationship with your pedal, so we offer a comprehensive 2-year warranty from the date of purchase. You can extend this warranty to 4 years by registering your product at <https://origineffects.com/register/>

Please note the warranty is not transferable and only valid for the original owner. Returns or servicing should be arranged through the store you purchased the product from. Proof of original ownership may be required in the form of a purchase receipt.

For full warranty details visit www.origineffects.com/warranty.