

BASSRIG

F I F T E E N

OWNER'S MANUAL



www.origineffects.com

ORIGIN EFFECTS is a trademark of Origin Effects Limited and is a registered trademark in the United States, United Kingdom, China and the EU.

The ORIGIN EFFECTS Totem Device is a trade mark of Origin Effects Limited and is a registered trademark in the United States, China and United Kingdom.

BASSRIG FIFTEEN is a trademark of Origin Effects Limited.

Ampeg® is a registered trademark of Yamaha Guitar Group, Inc. Origin Effects has no affiliation with Yamaha Guitar Group, Inc.

Portaflex® is a registered trademark of Loud Technologies, Inc. Origin Effects has no affiliation with Loud Technologies, Inc.

All other product names and trademarks are the property of their respective owners and are hereby acknowledged.

No part of this publication may be reproduced in any form or by any means, whether mechanical or electronic, without the written permission of Origin Effects Limited.

Origin Effects Limited reserves the right to change the features and specifications described herein without notice or obligation. Origin Effects Limited cannot be held responsible for any loss or damage arising directly or indirectly from any error or omission in this manual.

© Origin Effects Limited 2025

Origin Effects LTD
Unit 4, Top Angel, Buckingham
Buckinghamshire, MK18 1TH
United Kingdom



Contents

Safety Notices	4
Safety Instructions	5
Introducing the BASSRIG Fifteen	6
What is Amp Recreation?	6
Connecting Your BASSRIG Fifteen	7
BASSRIG Fifteen in Your Rig	8-9
BASSRIG Fifteen Internal Signal Flow Diagram	10
BASSRIG Fifteen Controls	11
BASSRIG Fifteen DI OUT	12
BASSRIG Fifteen AMP OUT EQ Controls	13-14
BASSRIG Fifteen AMP OUT EQ Frequency Response	15
Sample Settings	16
Appendix A: Physical Specification	17
Appendix B: Performance Specification	17
Appendix C: Connector Pin Out	17
Appendix D: Environmental Information	18
Appendix E: Directives & Regulations	18
Appendix F: Warranty	19

Safety Notices:

General Information:

This document contains important information for the safe operation of the product. Read and follow the safety instructions and all other guidance. Our products and documentation are subject to a process of continuous development. They are therefore subject to change. Please refer to the latest version of the documentation, which is available on our website <https://origineffects.com/manuals/>.

Keep these instructions and heed all warnings. Do not use this apparatus near water. Clean only with a dry cloth. Do not install near any heat sources such as radiators, stoves or other apparatus (including amplifiers) that produce heat. Refer all servicing to qualified service personnel.



NOTICE!

Damage may be caused to the device should it be tampered with!

No user-serviceable parts inside. In the event of damage to the unit, service or repair must be done by qualified service personnel only.

Symbols and signal words:

In this section you will find an overview of the meaning of symbols and signal words that are used in this document.

Signal Word	Meaning
DANGER!	This combination of symbol and signal word indicates a dangerous situation that could result in serious injury or even death if it is not avoided.
WARNING!	This combination of symbol and signal word indicates a potentially dangerous situation that could result in serious injury or even death if it is not avoided.
NOTICE!	This combination of symbol and signal word indicates a potentially dangerous situation that could result in material and/or environmental damage if it is not avoided.

Warning Symbol	Meaning
	Warning - dangerous situation

Safety Instructions:

Intended use:

This device is intended for use as effects pedal for sound processing of signals from musical instruments with electromagnetic pickups. Any other use or use under other operating conditions is considered to be improper and may result in personal injury or property damage. No liability will be assumed for damages resulting from improper use.

Safety:



DANGER!

Risk of injury and choking hazard for children!

Children can suffocate on packaging material and small parts. Never allow children to play with packaging material or the device. Always store packaging material out of the reach of babies and small children. Always dispose of packaging material properly when it is not in use. Never allow children to use the device without supervision. Keep small parts away from children and make sure that the device does not shed any small parts (such as knobs, rubber feet) that children could play with.



WARNING!

Possible hearing damage due to high volumes on speakers, headphones, bass & guitar amplifiers!

With loudspeakers or headphones connected, the device can produce volume levels that may cause temporary or permanent hearing impairment. Over an extended period of time, even levels that seem to be uncritical can cause hearing damage. Do not operate the device permanently at a high volume level. Decrease the volume level immediately if you experience ringing in your ears or hearing impairment and seek medical advice.



NOTICE!

Damage to device if powered incorrectly!

This product is designed to be powered from a 9VDC, >200mA power supply with 2.1mm centre-negative barrel connector. Use of an incorrectly rated power supply could result in damage to the pedal and the power supply.



NOTICE!

Possible staining due from rubber feet!

The plasticiser used in the manufacture of the rubber feet on this product may react with floor coatings and result in permanent dark stains after some time. If necessary, use a suitable mat to prevent direct contact between the device's rubber feet and the floor.

Introducing the BASSRIG Fifteen

The BASSRIG Fifteen is an all-analogue amp recreation, based on the legendary Ampeg® B-15 Portaflex® amplifier. Introduced in the early 1960s, the B-15 was the first dedicated bass combo amp and is still highly sought after today, with its low output power and unique cab making it the perfect choice for the studio. While its signature warm clean tones and subtle overdrive are synonymous with the sound of '60s soul records, it's at home in any genre that calls for a vintage bass tone. The BASSRIG Fifteen recreates the sound, feel and character of this timeless bass rig.

Familiar, responsive controls let you dial in instantly recognisable retro studio tones, while the BLEND control adds in clean signal for low-end clarity and extra articulation. An all-analogue cabinet simulation from the DI OUT make the BASSRIG Fifteen the perfect direct recording tool or direct-to-PA preamp, and the powerful AMP OUT EQ tailors the voicing of the pedal to suit any backline amp.

Key Features:

- Faithfully recreates the sound and feel of the Ampeg® B-15 amp
- Complete, valve amp-style signal path recreated in all-analogue circuitry
- Simulated push-pull power amp with reactive load
- All-analogue 1x15" cabinet simulator and DI output
- Extensive AMP OUT EQ controls ensure compatibility with any rig
- BLEND knob to mix in clean signal
- High-quality buffered bypass
- Premium components throughout
- Designed and built in England

What is an Amp Recreation?

Amp Recreation is the name we give to our range of all-analogue pedals that recreate the sound and feel of desirable vintage valve amplifiers. Our BASSRIG Amp Reproductions are all-in-one amp and cab simulations, and can be used as an "ampless" rig, direct to a PA or recording interface. They can also be used instead of an amp block in a modeller to give a more realistic amp tone. They can be used into a power amp and cab, and of course they can be run into the front end of a traditional amp.

When we say "Amp Recreation", we really mean it! Each Amp Recreation pedal contains the complete signal path of a vintage valve amplifier, except the valves! We use carefully designed transistor-based circuitry to capture every tiny detail of the real amps' circuitry, informed by many hours of meticulous testing and measurement with the original amps. These pedals contain a preamp stage, phase inverter, simulated push-pull power amp and reactive load. All these are crucial to providing the authentic tones and the playing experience of vintage amps.

The BASSRIG Amp Reproductions feature an analogue cabinet simulator and balanced DI OUT, and an AMP OUT EQ. These features allow you to run direct to a PA or recording interface, or tailor the sound going to your amp without having to compromise your amp's settings.

Connecting Your BASSRIG Fifteen

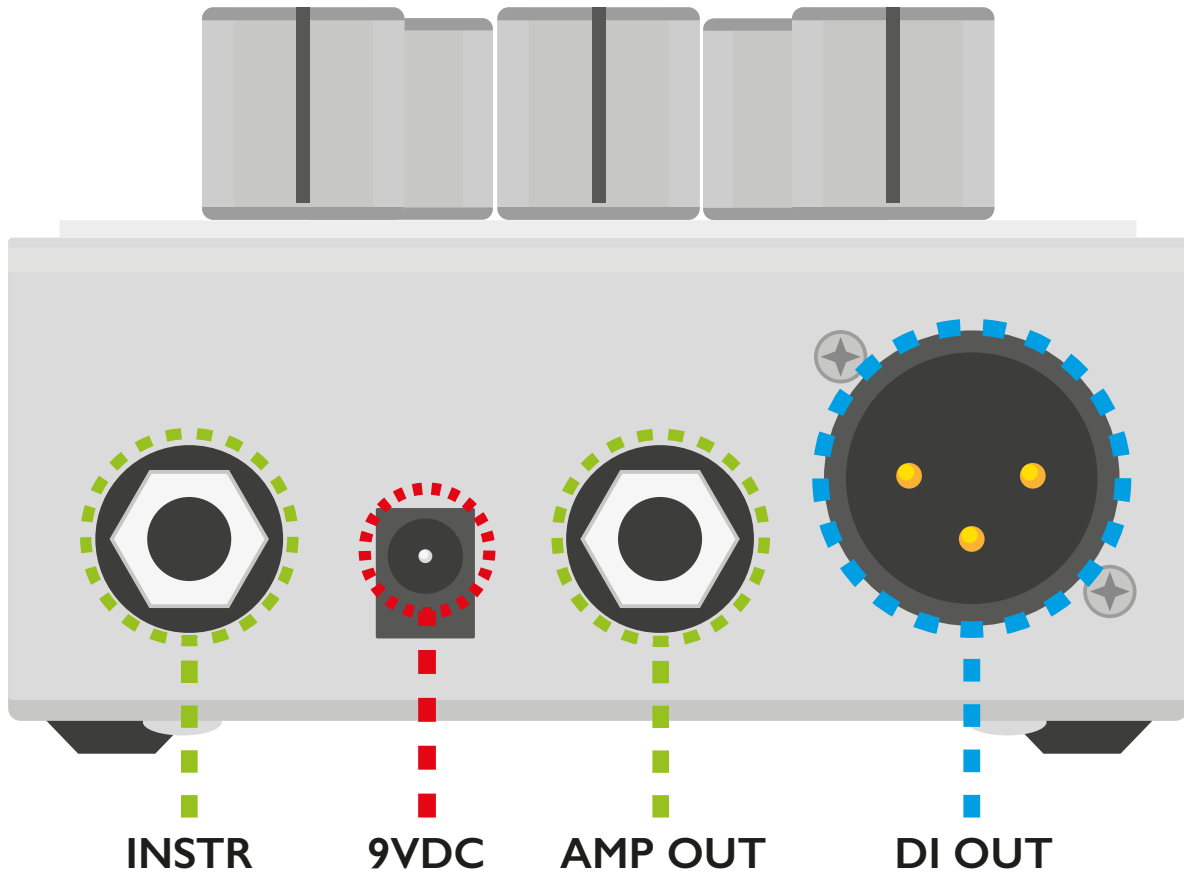

9VDC: Connect a 9VDC 2.1mm centre-negative mains power adaptor (minimum 200mA).



NOTICE!

Damage to device if powered incorrectly!

This product is designed to be powered from a 9VDC, >200mA power supply with 2.1mm centre-negative barrel connector. Use of an incorrectly rated power supply could result in damage to the pedal and the power supply.

INSTR: Connect to your bass, guitar or other instrument.

AMP: Connect to your amp or power amp.

DI OUT: Connect to your mixer, audio interface or PA system



WARNING!

Possible hearing damage due to high volumes on speakers, headphones, bass & guitar amplifiers!

With loudspeakers or headphones connected, the device can produce volume levels that may cause temporary or permanent hearing impairment. Over an extended period of time, even levels that seem to be uncritical can cause hearing damage. Do not operate the device permanently at a high volume level. Decrease the volume level immediately if you experience ringing in your ears or hearing impairment and seek medical advice.

BASSRIG Fifteen in Your Rig

BASSRIG Fifteen direct with a PA or recording setup:

The DI OUT is designed for compatibility with a wide range of microphone and line level inputs. Its output level is configured to prevent unwanted clipping at the mixer or interface to which the pedal is connected. If your PA mixer or recording interface has the ability to select between line and mic level, you should select mic level. If not, you may need to add some gain at the input of your mixer/interface.

When using the DI OUT only, the DI GROUND switch should be set to GND (see: Page 12 – DI OUT). For direct-to-PA gigs, we recommend setting the DI CAB SIM switch to ON or FX.

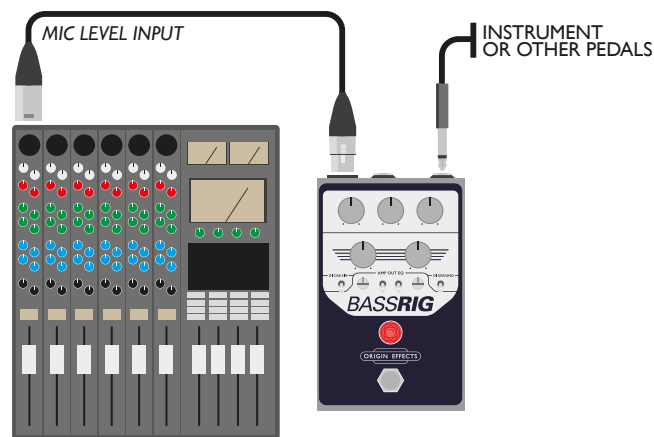

BASSRIG Fifteen with a bass amp:

The BASSRIG Fifteen's 1/4" AMP OUT is designed to work with a typical bass amp or power amp, paired with a bass cab. The AMP OUT can be connected either to the input of your bass amp, or to the FX Loop return, bypassing your amp's preamp altogether.

If you want to turn your BASSRIG on and off to go from a modern clean tone to a more vintage tone, it is better to connect to the input of your amp. This means you'll still have the tone-shaping of your amp available for dialling in your clean tone. If you intend to leave the BASSRIG active all the time as your "core tone", you might prefer to connect to the FX Loop return, bypassing your amp's preamp altogether.

The AMP OUT EQ helps tweak the sound from the AMP OUT to help your cab sound more like the cab of a B-15, and to even out the differences between different cabs, e.g. rented backline (see: Page 13 - AMP OUT EQ Controls).



BASSRIG Fifteen in Your Rig (continued)

BASSRIG Fifteen with a bass amp & PA/recording setup:

The BASSRIG Fifteen's AMP OUT and DI OUT can be used together to connect simultaneously to a PA system and an on-stage amp. This allows you to monitor your sound independently of what is being sent to the PA.

When running this setup, all the "Amp Recreation" controls (DRIVE, BLEND, OUTPUT, BASS and TREBLE) will affect both outputs, so it's best to set these once and leave them alone, otherwise any tweaks will change your sound in the PA too. Tweaks to your on-stage sound should be made either using the AMP OUT EQ controls or the controls on your amp.

When using both the DI OUT and AMP OUT, you may experience a ground loop hum. To eliminate ground loop hum, set the DI GROUND switch to LIFT.

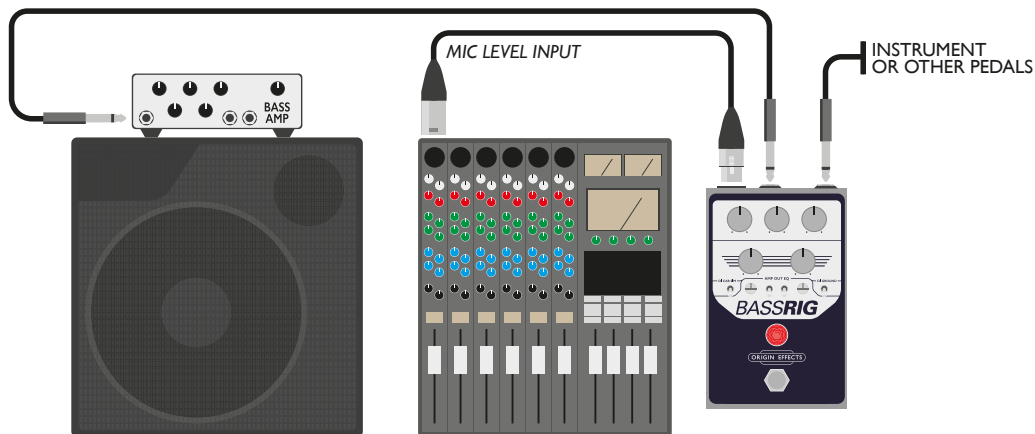

BASSRIG Fifteen with additional pedals:

When using the DI OUT, the BASSRIG should be the last pedal in your signal chain, as it is simulating an amplifier and speaker cabinet. If you are using the BLEND knob to add clean signal, any boost pedals used in front of the BASSRIG will also increase the volume of the clean signal.

If you are only using the AMP OUT, you can be more flexible with signal chain placement. In this case, we still recommend that the BASSRIG is placed after any pedals that you would use in front of an amp, for example: fuzz, wah, compression, overdrive, octave and filter. Time-based effects can be placed before or after the BASSRIG, depending on personal preference.



BASSRIG Fifteen Internal Signal Flow Diagram:

What goes into an amp Recreation? The diagram below shows how the different parts of the Ampeg® B-15 have been recreated in the BASSRIG Fifteen. For example, all the parts of the circuit that recreate valve stages are affected by simulated rectifier sag.

After the Amp Recreation circuitry, the signal is split. The cabinet simulator is applied to the DI OUT only, and the AMP OUT EQ is applied to the AMP OUT only.

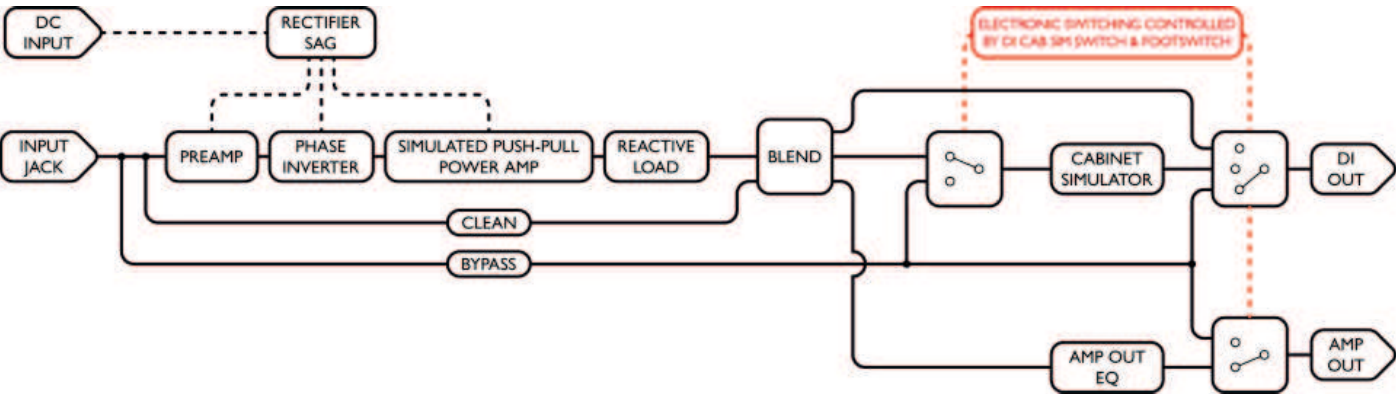

BASSRIG Fifteen controls

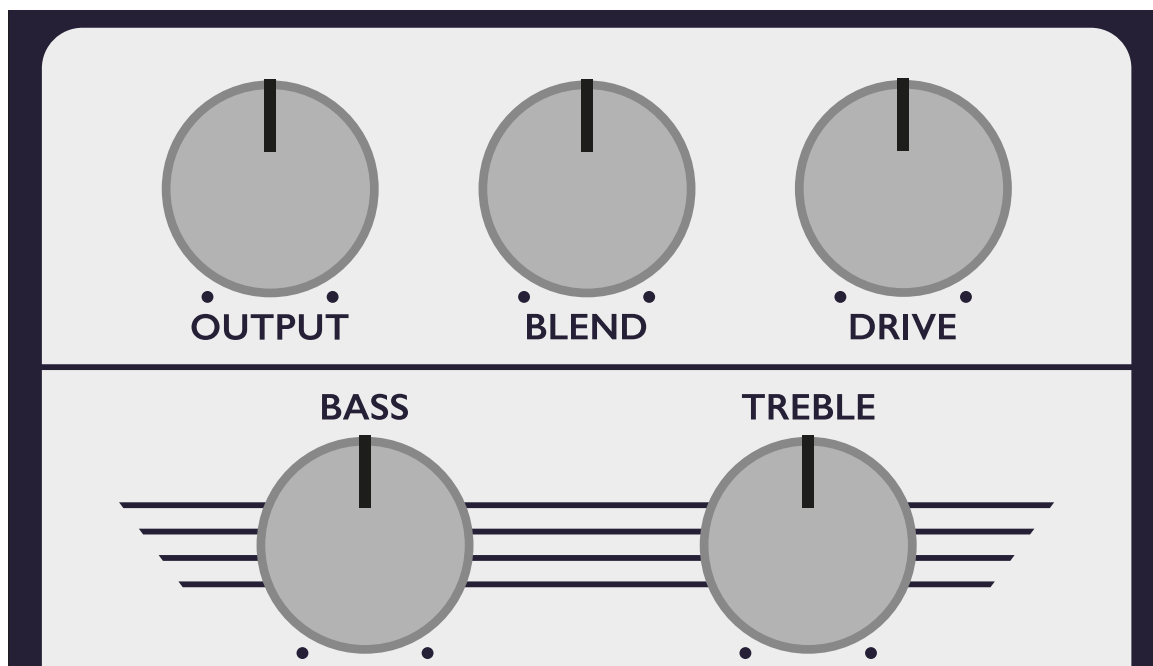

DRIVE: The gain control functions exactly like the volume knob on a non-master-volume valve amp. Turn it clockwise for more gain, drive and distortion. Turn counterclockwise to clean things up.

BLEND: This control blends your clean signal in parallel with the recreated amp tone. When set full clockwise, there is no clean signal mixed in. Turn counterclockwise to progressively mix in your clean signal. This can help add definition to your tone, especially in the low end when using overdriven sounds.

OUTPUT: The output control sets the pedal's overall output level. This control is not part of the BASSRIG's recreated amp circuitry so it will not alter the pedal's overdrive character. It simply makes the pedal louder or quieter.

TREBLE: Just like on the original Ampeg® B-15, the tone controls are placed before the overdrive. Turning the TREBLE control up will not only increase top end but also change the character of the overdrive, making it grittier and more aggressive. Turning this control down will result in a warmer tone and softer overdrive.

BASS: This control adjusts the amount of low frequencies as well as how “tight” or “thick” overdriven tones are. In general, higher BASS settings work better with cleaner sounds. More overdriven sounds can benefit from having the BASS turned down, preventing the distortion from becoming too “wooly”. But there are no rules – use a clean sound with the BASS set low for a more percussive tone, or turn the DRIVE and BASS up for fuzzier sounds.

BASSRIG Fifteen DI OUT

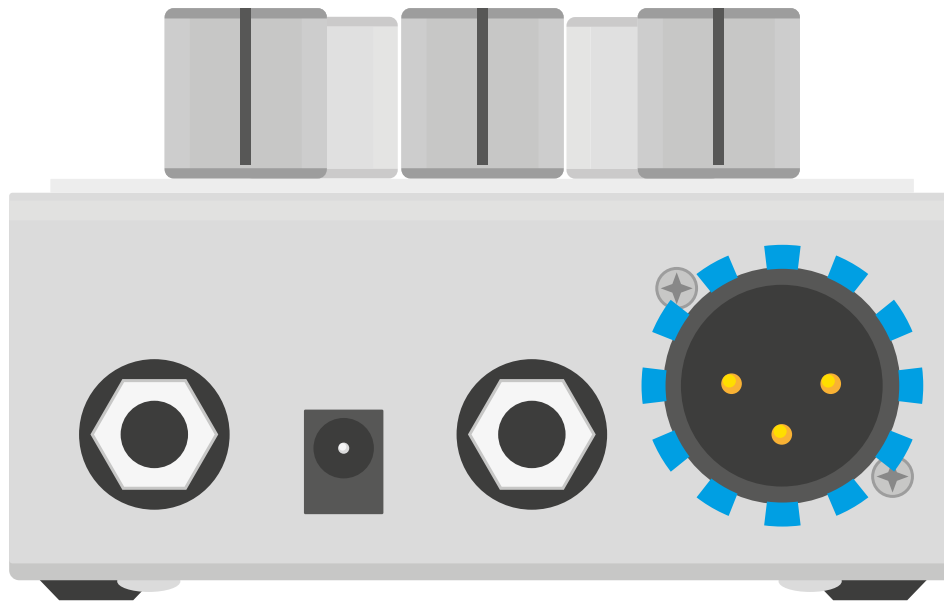

This DI OUT is a balanced XLR output equipped with an all-analogue cabinet simulator, accurately capturing the response of the B-15's 1x15" speaker cabinet. Using this output gives you the complete sound of a mic'd B-15 direct to your recording console or PA system.

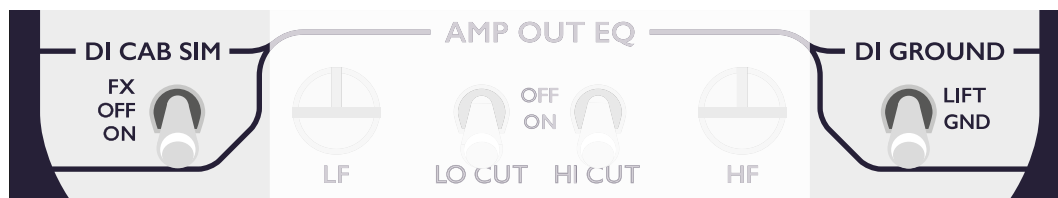

DI CAB SIM switch: Lets you select when the cab sim is active.

FX: Cab sim is only active when the pedal is active. This lets you use the BASSRIG as an accurate amp simulator when engaged and as a completely flat DI when bypassed.

ON: Cab sim stays active even when the BASSRIG is bypassed. This lets you use the BASSRIG as a cabinet simulator for other preamp and drive pedals.

OFF: Cab sim is always bypassed. This is useful for using an external cabinet simulator, or for recording a non-cabinet simulated signal which you can process later.

DI GROUND switch: Lifts the ground of the DI OUT. This is necessary to avoid unwanted ground loop hum when connecting the BASSRIG to multiple pieces of equipment (e.g. a bass amp and a PA system). If you hear a hum when connecting the BASSRIG to two pieces of equipment, set this switch to LIFT. If you are only connecting the BASSRIG's DI OUT, this should be set to GND. This switch does not affect the AMP OUT.

BASSRIG Fifteen AMP OUT EQ controls

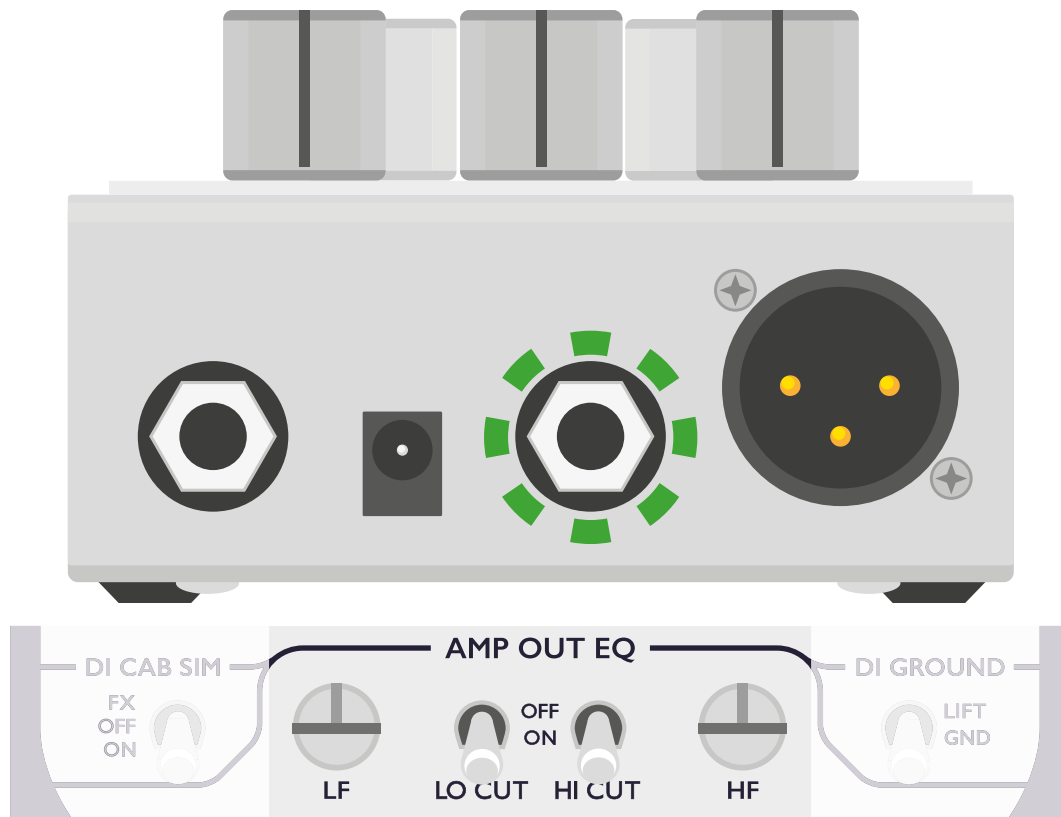

AMP OUT EQ CONTROLS: The post-drive AMP OUT EQ ensures compatibility with a wide range of amps and cabs. When using the DI OUT in conjunction with the AMP OUT, the AMP OUT EQ can help your on-stage amp sound like your DI signal. When using the BASSRIG Fifteen more like a traditional overdrive pedal, these controls can help balance the BASSRIG's tone with the clean settings on your amp.

HI CUT SWITCH: This switch engages a low-pass filter for use with tweeter-equipped cabs. This allows a modern, full-range cab to sound much more like a vintage cab and prevents the “fizzy” parts of an overdriven sound from reaching the tweeter. This is useful if you have a cab where you can't turn the tweeter off, or when you want to toggle between a hi-fi clean tone and a vintage overdrive sound.

LO CUT SWITCH: Part of the Ampeg® B-15's signature sound is the tight low-end roll-off from its small 1x15" cab. Engaging the LO CUT switch applies that low-end roll-off to the BASSRIG's AMP OUT, giving any modern cab a low frequency response like that of the B-15. Great for backline amps or when toggling the BASSRIG on and off to go from a full-range modern tone to a vintage-flavoured sound.

HF: This post-drive high frequency control cuts or boosts upper-mid and treble frequencies. This is perfect for adjusting the BASSRIG's high-end response to match your clean tone, adding some vintage speaker character to a modern cab or fine-tuning the effect of the HORN CUT filter.

LF: This post-drive low frequency control cuts or boosts bass frequencies. This is perfect for adjusting the BASSRIG's low-end response to match your clean tone, fattening up a small cab or taming excessive boominess in a big cab.

See Page 15 for AMP OUT EQ frequency response.

BASSRIG Fifteen AMP OUT EQ controls (continued)

Setting your AMP OUT EQ:

Use the tables below to help you set up the BASSRIG Fifteen for the first time with your rig. Working through the steps below allows you to “set-and-forget” the AMP OUT EQ controls and focus on dialling in your ideal tone with the main controls.

Step 1: Set HI CUT for the connected amp or device

Amplifier or Connected Device	HI CUT Switch Position
Amplifier and tweeter-equipped cab	ON
Amplifier and non-tweeter-equipped cab	OFF
Direct to mixer, PA or interface from DI OUT	The HI CUT does not affect this output

Step 2: Set LO CUT for the connected amp or device

Amplifier or Connected Device	LO CUT Switch Position
Full-range, modern sounding cab	ON
Tighter sounding, smaller cab	OFF
Direct to mixer, PA or interface from DI OUT	The LO CUT does not affect this output

Step 3: Fine-tune the AMP OUT EQ with the LF and HF controls

How is the BASSRIG Fifteen's Tone?	LF/HF Control Position
I used the HI CUT switch and my tone is still too fizzy	Try turning the HF control counterclockwise
I used the HI CUT switch and now my tone is too dull	Try turning the HF control clockwise
I used the LO CUT switch and my tone is still too boomy	Try turning the LF control counterclockwise
I used the LO CUT switch and now my tone is too thin	Try turning the LF control clockwise
It's perfect!	Great! Stop tweaking and start playing!

BASSRIG Fifteen AMP OUT EQ Frequency Response

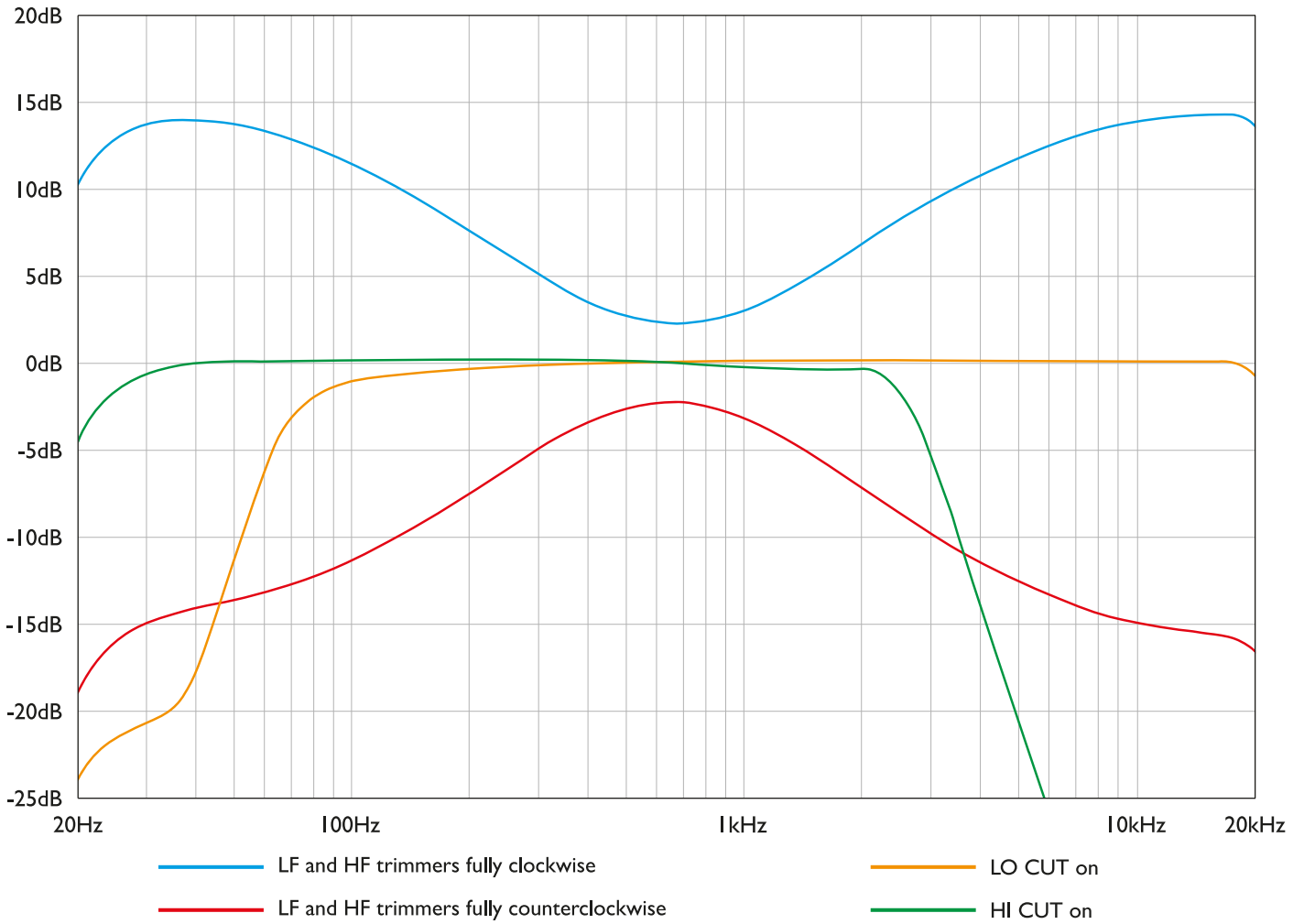

Sample Settings



SOUL PUNCH

The quintessential B-15 sound, heard on the greatest soul records. With moderate EQ settings, this tone is warm and punchy, with enough gain to break up a little when you dig in.



RETRO ROCK

B-15s can rock too! Cranking the TREBLE knob gets you a biting, gritty drive sound that's never too harsh, while the tight low end keeps things controlled and percussive.



DEEP CLEAN

A big BASS boost is nicely balanced by the cab sim's natural roll-off, giving you a fat, vintage-flavoured clean tone that's full of character and sits just right in the mix.



FUZZED OUT

Turn up the DRIVE and cut some BASS for a gnarly distorted tone! Adding clean signal with the BLEND knob restores definition and keeps the low end sounding full.

Appendix A: Physical Specification

Measurement	Unboxed	Boxed
Weight	846g (30oz)	930g (33z)
Length	146mm (5.7")	160mm (6.2")
Depth	93mm (3.6")	116mm (4.5")
Height	64mm (2.5")	95mm (3.7")

Appendix B: Performance Specification

Measurement	Value
Input impedance	1M Ω
AMP OUT impedance	500 Ω
DI OUT impedance	1k Ω
Current draw	200mA
Power supply requirements	9VDC 2.1mm centre negative connector

Appendix C: Connector Pin Out

DI OUT male XLR:

Pin	Description
Pin 1	Ground
Pin 2	Positive
Pin 3	Negative

Instrument and Amplifier 1/4" TS Sockets:

Pin	Description
Tip	Signal
Sleeve	Ground

Appendix D: Environmental Information

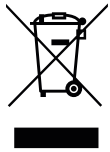

The crossed out wheely bin symbol indicates this product is classified as Waste Electrical and Electronic Equipment (WEEE) in the European Union and should not be discarded with household waste. Other territories may vary. Contact your local authority or Origin Effects for more information.



The packing materials for this product are recyclable. Do not dispose of these materials with your normal household waste. Please refer to the symbols on the packaging for recycling information. Contact your local authority for further guidance on recycle in your region.

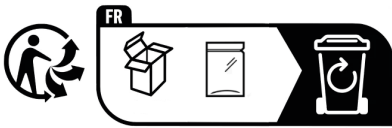

Les matériaux d'emballage sont recyclables.



Points de collecte sur www.quefairemesdechets.fr
Privilégiez la réparation ou le don de votre appareil !

Appendix E: Directives & Regulations



This product complies with Electromagnetic Compatibility (EMC) directive 2014/30/EU.



Origin Effects Ltd has conformed where applicable to European Union's Directive 2011/65/EU on Restrictions of Hazardous Substances (RoHS) as well as the following sections of California law which refer to RoHS, namely sections 25214.10, 25214.10.2, and 58012, Health and Safety Code; Section 42475.2, Public Resources Code.



This equipment has been tested and found to comply with the limits for a Class B device, pursuant to part 15 of the FCC Rules. These limits are designed to provide reasonable protection against harmful interference in a residential installation. This equipment generates, uses and can radiate radio frequency energy and, if not installed and used in accordance with the instructions, may cause harmful interference to radio communications. However, there is no guarantee that interference will not occur in a particular installation. If this equipment does cause harmful interference to radio or television reception, which can be determined by turning the equipment off and on, the user is encouraged to try to correct the interference by one or more of the following measures:

- Reorient or relocate the receiving antenna.
- Increase the separation between the equipment and receiver.
- Connect the equipment into an outlet on a circuit different from that to which the receiver is connected.
- Consult the dealer or an experienced radio/TV technician for help.

Appendix F: Warranty

This product is covered by a 2-year manufacturer's warranty from the date of purchase. This applies only to original purchasers who have bought their product from an authorised Origin Effects dealer or directly from Origin Effects.

All returns or servicing should be arranged through the original dealer. Proof of original ownership may be required in the form of a purchase receipt.

For full warranty details visit www.origineffects.com/warranty.